

## Installation instructions

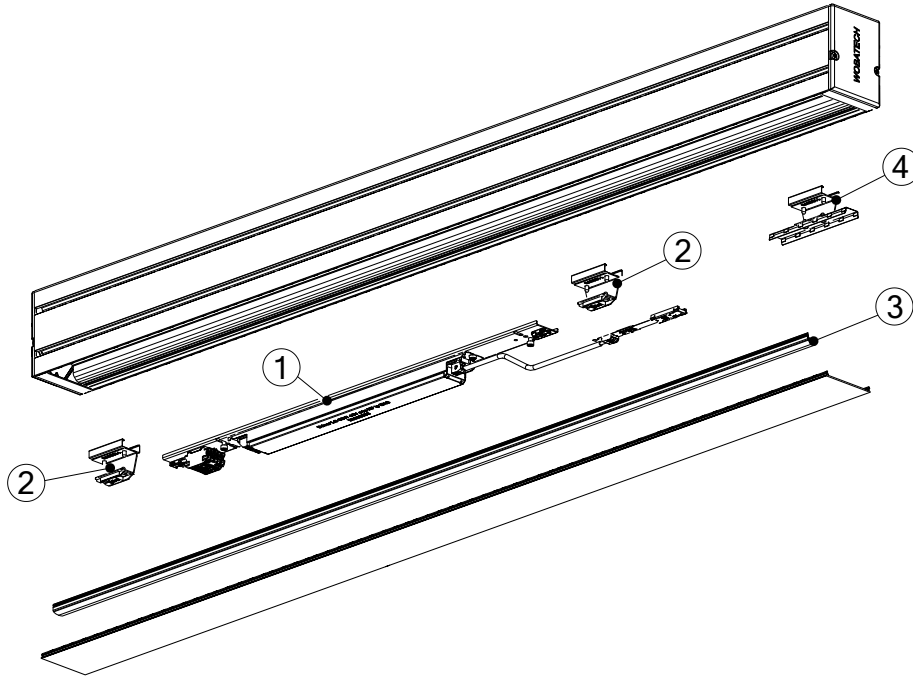

**smarterion**

**SCHWEIZER LED KOMPETENZ**



Item	Art. No.	Type
1	1100067	Netzteileinschub 60W
	1100068	Netzteileinschub 100W
2	1100070	Montageklammer
3	1007652	LED Modul 827
	1007653	LED Modul 830
	1008062	LED Modul 835
	1007654	LED Modul 840
4	1100105	Modul Verbinder

# Installation instructions



1

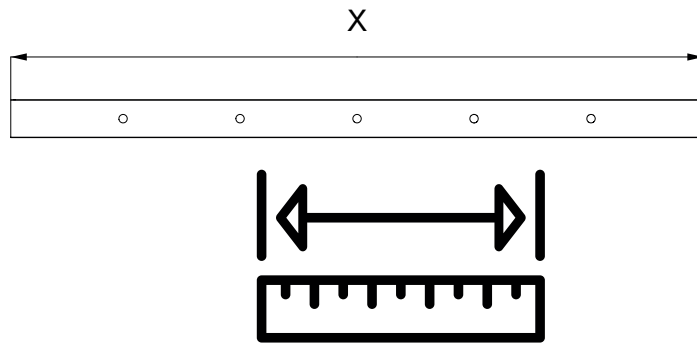

2

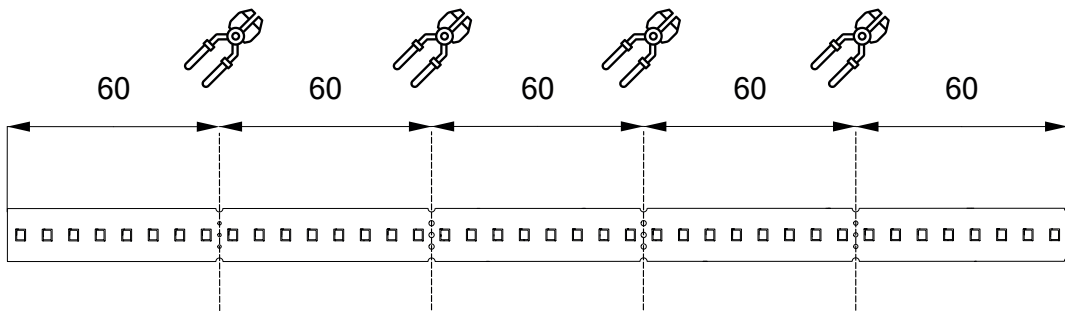

i

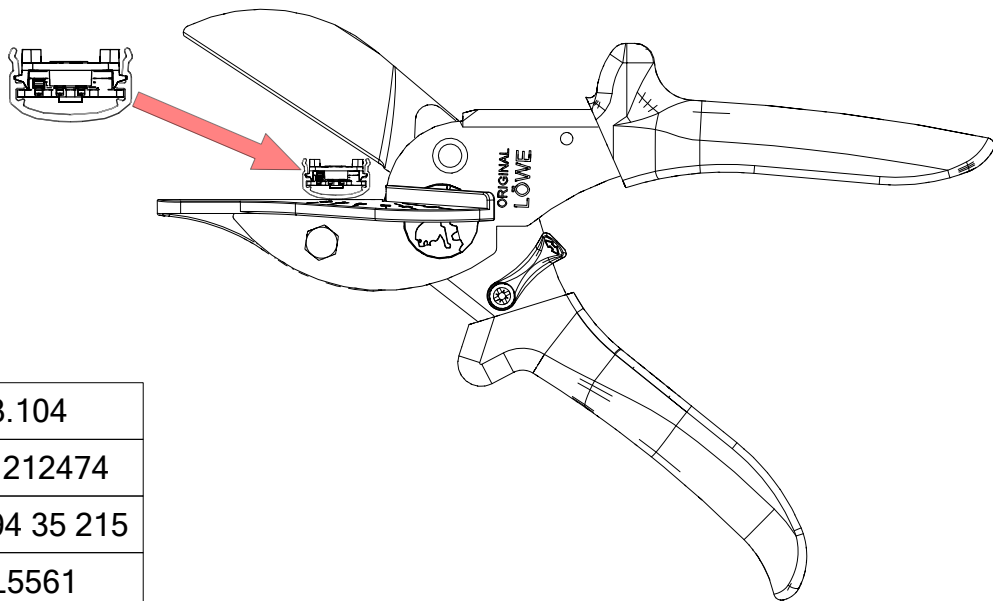

Löwe	3.104
Phönix	1212474
Knipex	94 35 215
Hager	L5561

# Installation instructions

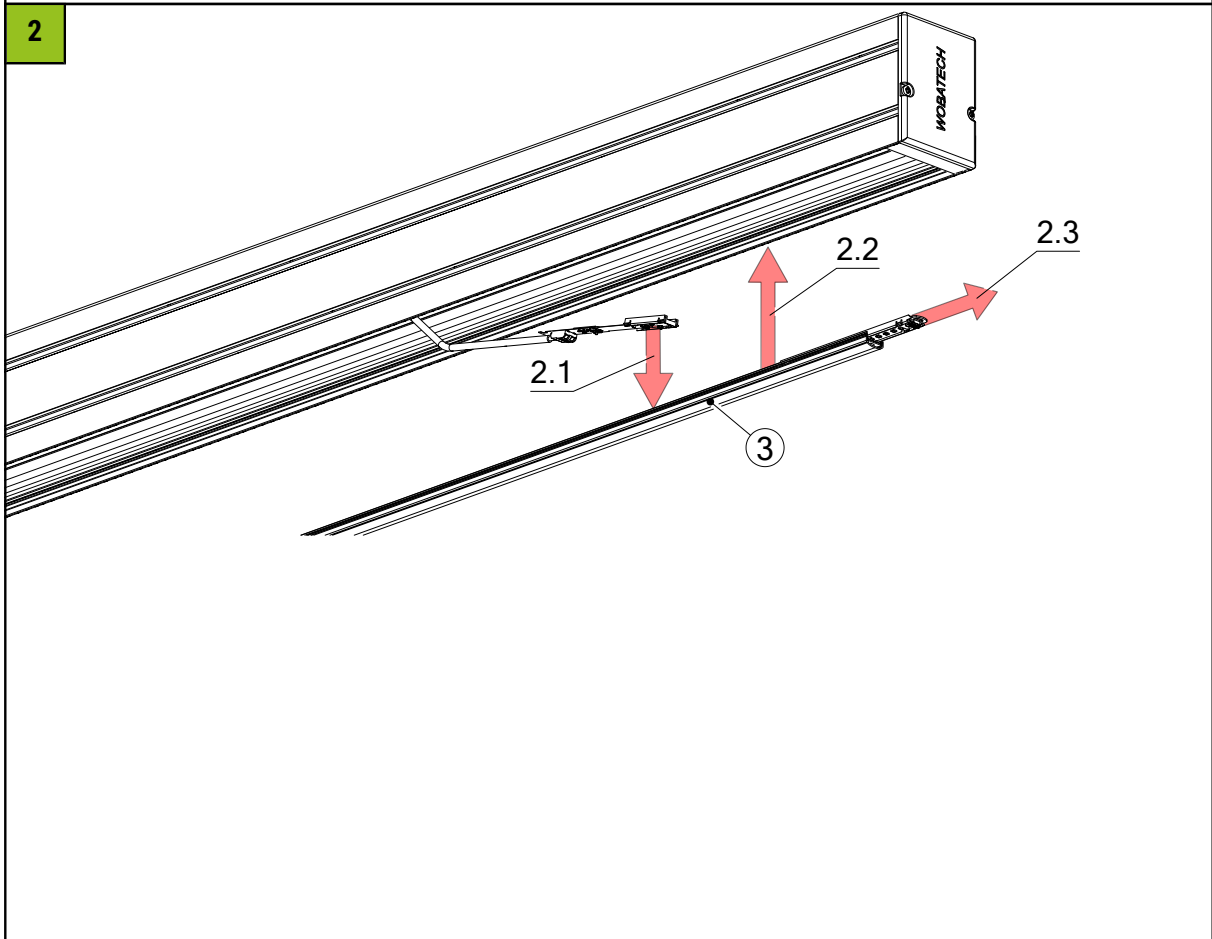
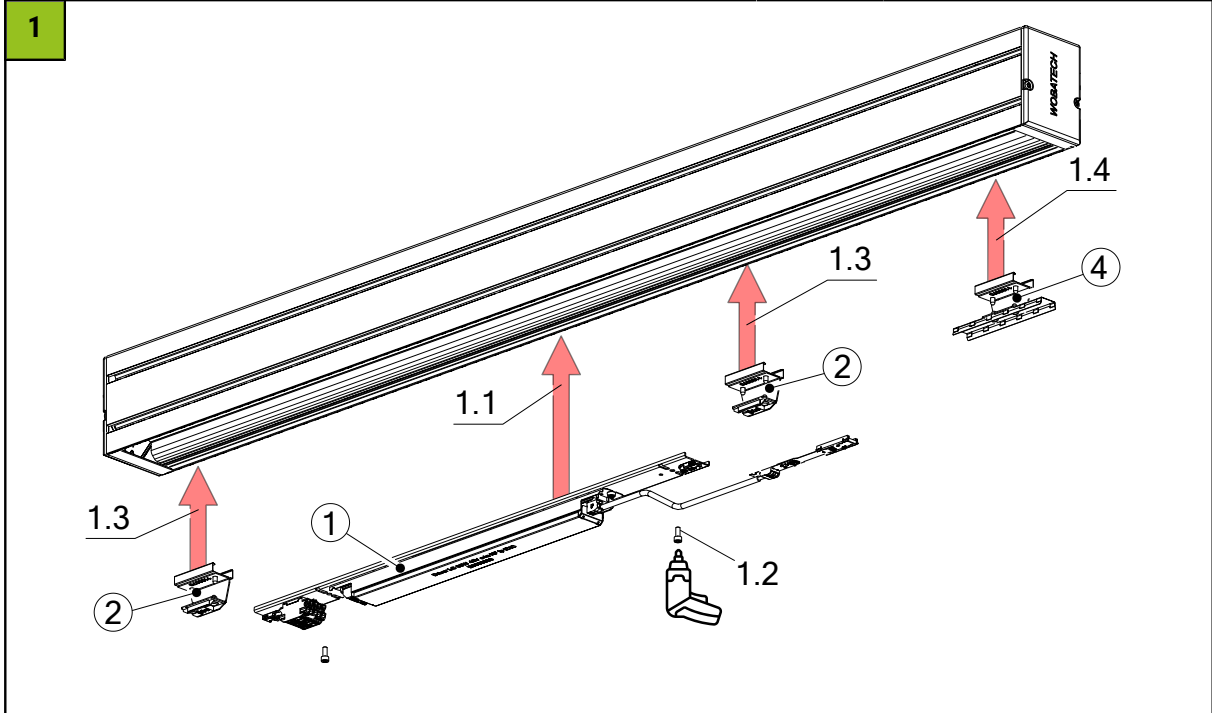
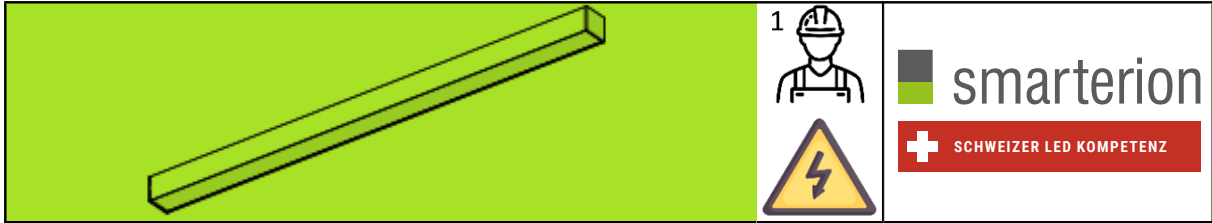

## Installation instructions

**i**

single white (SW):

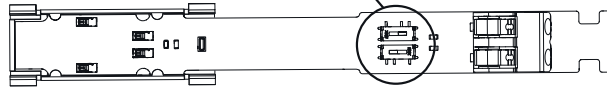
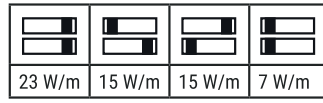

Power supply	7W/m	15W/m	23W/m
100W	14 m	6.5 m	4 m
60W	8.5 m	4 m	2.5 m

**i**

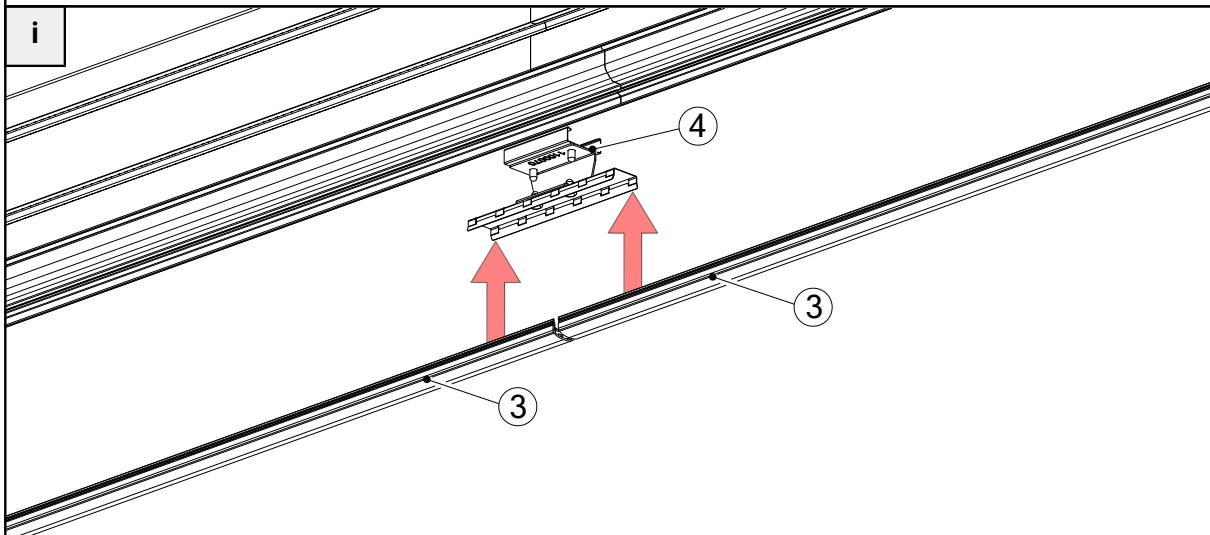

**i**

## Installation instructions

### Cleaning and care

Clean the luminaire with a damp, lint-free cloth. Do not scrub! In case of heavy soiling, a weak soapy solution can be used (microfiber cloth with detergent). Do not use abrasive cleaners. Do not wipe the light dry, as the resulting static charge can destroy the electronics.

### Warnings

Installation, commissioning and maintenance may only be carried out by authorized specialist personnel in accordance with these installation instructions and all applicable standards and regulations for the respective area of application. Ensure the electrical, mechanical and thermal suitability of the luminaire for the intended area of application and check that the luminaire is securely fastened after installation. The luminaire is intended solely for lighting purposes; any other use or installation is considered not as intended. Failure to observe the installation instructions may result in the destruction of the luminaire. We reserve the right to make technical changes. The light must be disconnected from the mains before any work is carried out on it. The manufacturer is not liable for damage resulting from incorrect installation, improper operation or unauthorized modifications to the luminaire.

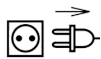

Disconnect the luminaire from the power supply.



Caution, risk of electric shock!



### DISPOSAL

The packaging must be recycled via the DSD (Green Dot) scheme or its equivalent. Dispose of the packaging correctly sorted. Waste electrical and electronic equipment must never be disposed of together with household waste. In accordance with the EU directives, the device must be disposed of in an orderly manner at the end of its service life. This means having the materials contained in the device recycled to avoid polluting the environment. Take the waste equipment to a collection point for electrical and electronic waste or to a recycling depot. For further information, please contact your local waste disposal service or your local authority.



To avoid hazards, only LED converters approved by us may be used, otherwise all warranty claims will be invalidated. Exceptions can be approved by the manufacturer.

Permitted LED converters:

- smarterion Triac Power supply units
- Meanwell, HLG
- Tridonic LC/LCA



Light source replaceable by end user.

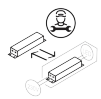

Control gear can be replaced by a specialist: The transformer must be replaced by a qualified electrician.